

HeartFelt® modular felt Baffle Ceiling System

PRODUCT CHARACTERISTICS:

- Modular felt baffle system
- Baffle dimensions 100 - 500 mm height, width 40 - 80 mm, length up to 1900 mm
- Multiple baffle and end caps options
- Five shades of Grey
- Suspended via a carrier rail
- Flexible acoustics

Project : Architect Office TOA, Paris, France
Product : HeartFelt® - modular felt Baffle Ceiling System
Architect: TOA

www.hunterdouglasarchitectural.eu

© Registered trademark - a HunterDouglas® product

HunterDouglas 
Architectural

SYSTEM OVERVIEW

- 1 = Baffle
 - 2 = End cap
 - 3 = Baffle (closed)*
 - 4 = Baffle (Open)
 - 5 = Mounting profile
 - 6 = Mounting clip
 - 7 = Carrier
 - 8 = Stabilisation bracket
 - 9 = Stabilisation profile
 - 10 = Quick hanger
 - 11 = Wire hanger
- * Length restrictions

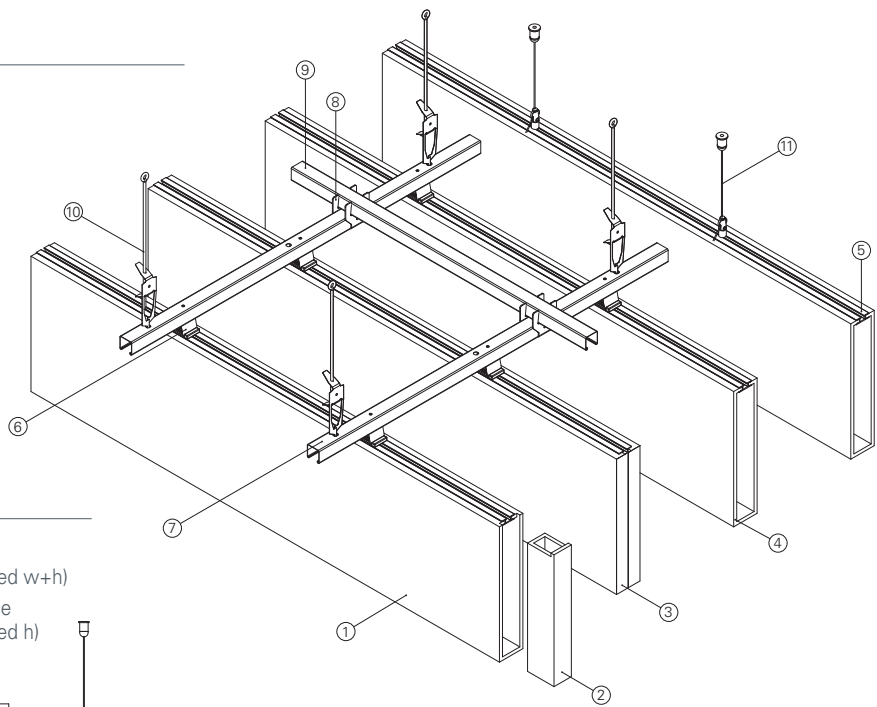

DETAILS

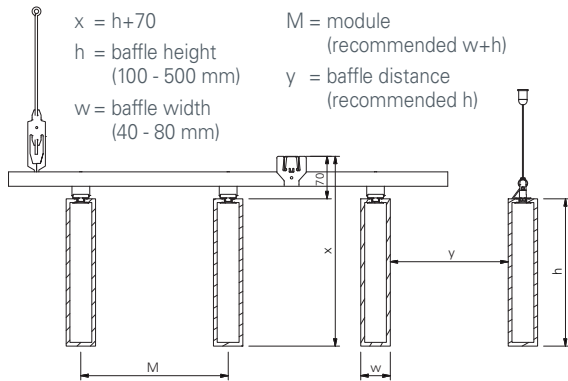

MAXIMUM SPAN

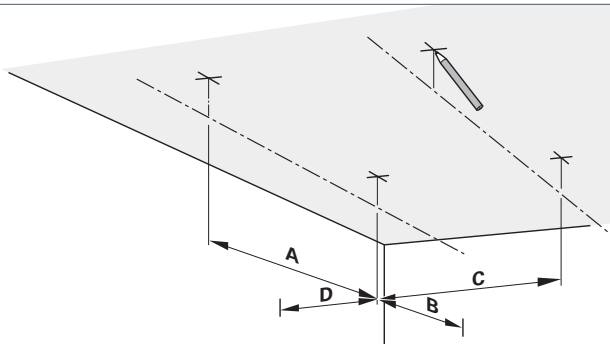

Panel	Maximum Carrier span		Maximum Panel span	
	A	B	C	D
HeartFelt® Baffle	1200	300	1900	500

MATERIAL PROPERTIES

- **Material:** non-woven, thermo formable PES-fibers
- **Fire retardant:** class B-s1,d0 EN 13501-1
- **Weight:** 5.0 kg/m² (80HB100 - M190)
2.4 kg/m² (40HB500 - M540)
- **Light reflection:** depending on colour
- **Exposure class:** A and B EN 13964

CERTIFICATIONS

- Indoor Air Comfort Gold
- French VOC-regulation class A+
- Cradle to Cradle™ Level Bronze
- Oeko-tex Standard 100 klasse IV
- SundaHus Miljødata klasse A
- GreenGuard Gold



ACOUSTICS

Baffle option 1 - Sound absorption baffle ceiling (α_w)

Baffle type	Module	Mounting	α_w	SAA/NRC	Class
50HB250	M250	Type A	0.50 (H)	0.60	D
50HB250	M500	Type A	0.45 (H)	0.49	D

Baffle option 2

Equivalent sound absorption per element (m² O.W.)

The table below shows the test results for Baffle panels:

- Length 1800 mm.
- Mounting type A

Baffle type	Module	125 Hz	250 Hz	500 Hz	1000 Hz	2000 Hz	4000 Hz
40HB200	random	0.11	0.35	0.59	0.60	0.76	0.81
50HB250	random	0.16	0.50	0.67	0.76	0.92	0.97
80HB400	random	0.41	0.79	0.90	1.19	1.31	1.43
50HB250	250	0.09	0.25	0.27	0.36	0.49	0.52
50HB250	500	0.16	0.38	0.44	0.54	0.73	0.76

Note: 50HB250 baffle, width = 50 mm and height = 250 mm

HunterDouglas Architectural

Hunter Douglas Architectural

Piekstraat 2
 P.O. Box 5072 - 3008 AB Rotterdam - The Netherlands
 Tel. +31 (0)10 - 486 99 11 - Fax +31 (0)10 - 484 79 10
www.hunterdouglasarchitectural.eu